

"innovation in its most functional form"

PRODUCT DATA SHEET



HP350S

HYDRAULIC SINGLE PORT SEALED HAND PUMP

PRESSURE RATING:

1st STAGE: 13.8 bar (197 psi)

2nd STAGE: 700 bar (10,000 psi)

CAPACITY: 350cc

TOOL WEIGHT = 4kg (8.82lbs)

KIT COMPONENTS

- 1 x HP350S Pump Unit
 - 1 x 0-1000 bar (0-15,000 psi) Gauge
 - 1 x 3/8" Port Gauge Adaptor
 - 1 x Instruction Manual
 - 1 x Cardboard Packaging
- Product Code: HP350SMIN



MODEL	HP350S	
PUMP TYPE	TWO SPEED	
PRESSURE RATING (bar/psi)	1ST STAGE	13.8 (197)
	2ND STAGE	700 (10,000)
USABLE OIL CAPACITY (cc/in ³)	350.0 (21.35)	
OIL VOLUME PER STROKE (cc/in ³)	1ST STAGE	13.0 (0.79)
	2ND STAGE	2.8 (0.17)
MAX HANDLE EFFORT (kg/lb)	25 (55.12)	
PISTON STROKE (mm/in)	18.0 (0.71)	

TOOL DESCRIPTION

The HP350S hydraulic hand pump unit is tailored for use with Equalizer International hydraulic equipment. It's output is regulated to 700 bar (10,000 psi) and is delivered from an output port threaded 3/8" NPT. The pump can be used with any 700 bar (10,000 psi) rated hydraulic equipment with an oil capacity of 350cc (21.35 in³) or less. The diaphragm oil reservoir means that, unlike conventional hand pump units, the HP350S is operable at all angles and is highly resistant to accidental spillage of hydraulic fluid. For further details please request an instruction manual.

WEIGHTS AND DIMENSIONS

- Tool Only = 4 kg (8.82 lbs)
- GROSS KIT WEIGHT = 4.5 kg (9.92 lbs)

Packaging Dimensions:

180 x 180 x 600 mm (7.09" x 7.09" x 23.62")

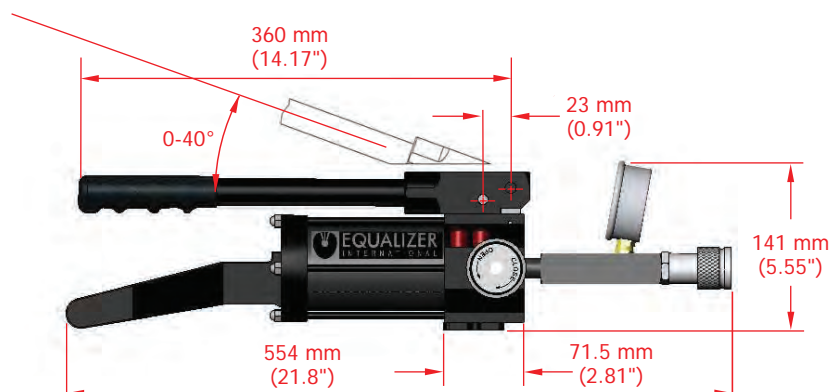
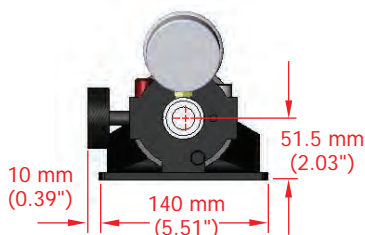

HP350S

HYDRAULIC SINGLE PORT

SEALED HAND PUMP



"innovation in its most functional form "

RANGE OF APPLICATION

All hydraulic equipment with an oil capacity of 350cc (23.13 in³) or less and an operating pressure of 10,000 psi (700 bar)

PARTS LIST AND EXPLODED DRAWING

ITEM	PART No.	DESCRIPTION	KIT QUANTITY	PUMP QUANTITY
01	710101-01	PUMP HOUSING		01
	715100-01	SERVICE KIT A:		
02		- OIL FILTER	01	01
03		- O-RING	01	01
04		- RESERVOIR BLADDER	01	01
05		- REFILLING PLUG	01	01
06	710601-01	RESERVOIR		01
	725200-01	SERVICE KIT B:		
07		- TAIL BASE	01	01
08		- SCREW	04	04
09		- SPRING WASHER	04	04
10		- NUT	04	04
	715300-01	SERVICE KIT C:		
11		- O-RING	01	01
12		- BACK-UP RING	01	01
13		- PUMP PISTON	01	01
14		- SNAP RING	01	01
15		- O-RING	01	01
16		- BACK-UP RING	01	01
17		- PUMP PISTON	01	01
	715400-01	SERVICE KIT D:		
18		- HANDLE	01	01
19		- YOKE	01	01
20		- PISTON PIN	01	01
21		- YOKE PIN	01	01
22		- RETAINING RING	01	01
23		- HANDLE GRIP	01	01
24		- SCREW	01	01
	715500-01	SERVICE KIT E:		
25		- YOKE BASE	01	01
26		- SPRING PIN	01	01
	715600-01	SERVICE KIT F:		
27		- RELEASE VALVE	01	01
		- SCREW		
28		- WASHER	01	01
29		- SEAL	01	01
30		- SCREW	01	01
31		- RELEASE KNOB	01	01
32		- COUPLERS	01	01
33		- CHECK BALL	01	01
	715700-01	SERVICE KIT G:		
34		- SPRING	02	02
35		- STEEL BALL	02	02
36		- OUTLET BALL SPRING	02	02
37		- COPPER WASHER	02	02
38		- VALVE COVER SCREW	02	02
39		- STEEL BALL	02	02

ITEM	PART No.	DESCRIPTION	KIT QUANTITY	PUMP QUANTITY
	715800-01	SERVICE KIT H:		
40		- STEEL BALL	01	01
41		- SPRING END CAP	01	01
42		- L.P. SPRING	01	01
43		- O-RING	02	02
44		- OVERLOAD COVER	01	01
		- SCREW		
45		- CAP	02	02
46		- OVERLOAD COVER	01	01
		- SCREW		
47		- CONE SEAT	01	01
48		- CONE	01	01
49		- LONG SEPARATOR	01	01
		- SPRING		
	715900-01	SERVICE KIT I:		
50		- BASE PLATE	01	01
51		- SCREW	02	02
	716100-01	SERVICE KIT K:		
52		- SCREW	04	03
53		- SCREW	01	01
24		- SCREW	01	01
33		- CHECK BALL	04	03
	716200-01	SERVICE KIT L:		
54		- GAUGE COUPLER	01	01
		- MALE		
55		- GAUGE	01	01
	716300-01	SERVICE KIT M:		
56		- GAUGE COUPLER	01	01
		- FEMALE		
57		- COUPLER	01	01
58		- GAUGE PORT	01	01
		- ADAPTOR		

